

## ■ SCOPE OF WORK

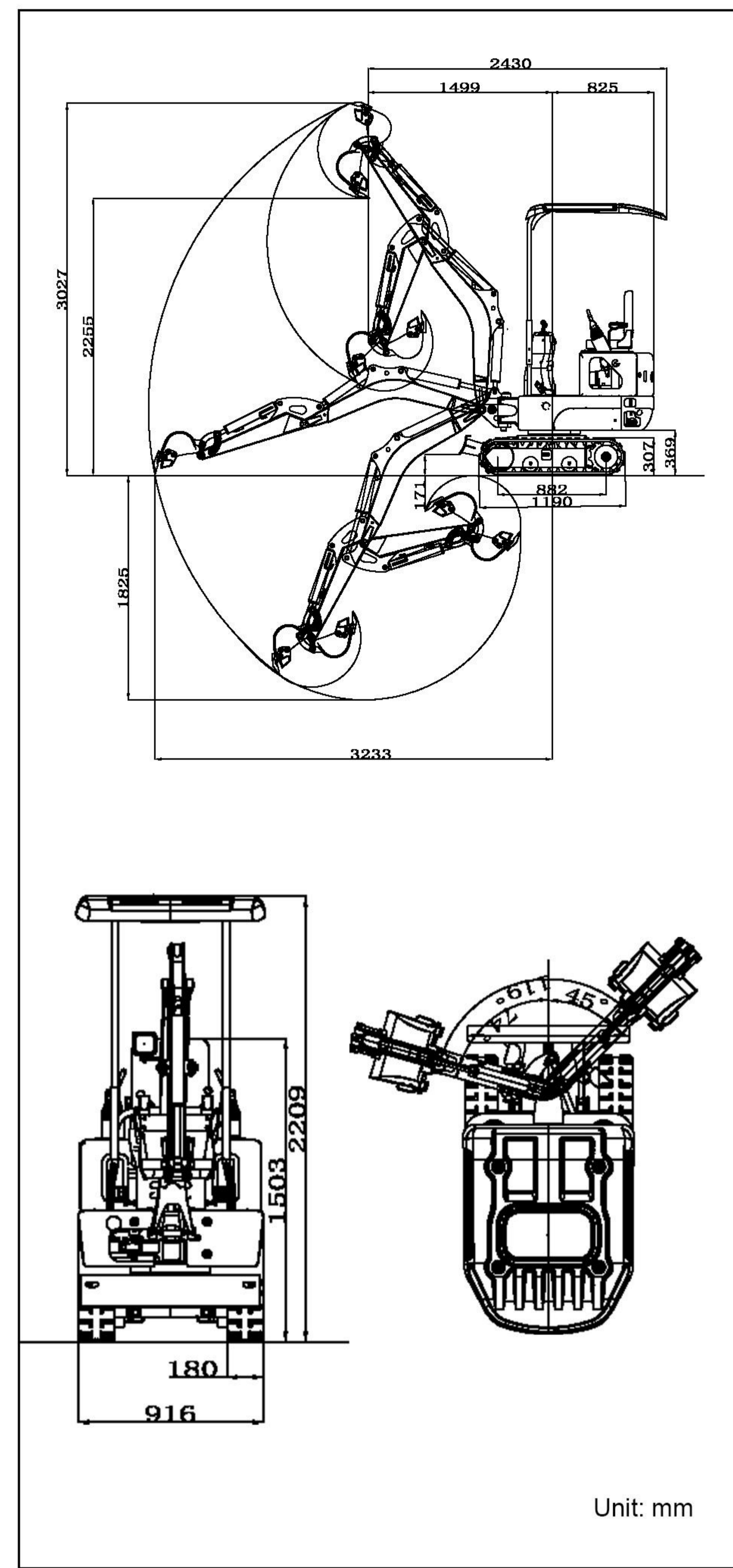

## ■ SPECIFICATION

	Model	US	R10 ECO
Basic parameters	Machine working weight	2244lb	1018kg
	Bucket capacity	0.49ft <sup>3</sup>	0.014m <sup>3</sup>
	Travel speed low/high speed	0-0.93mph	0-1.5km/h
	Gradeability	30%	30%
	Ground pressure	3.7psi	25.53Kpa
	Maximum digging force	9.2kN	9.2kN
	Maximum digging radius	127.3in	3233mm
	Maximum digging depth	72.2in	1833mm
	Maximum digging height	118.9in	3021mm
	Maximum unloading height	88.5in	2247mm
Maximum deflection angle	121°	121°	
Track extension range	35.4-47.2in	900-1200mm	
Engine	Engine brand	Kubota	Kubota
	Engine model	Z482	Z482
	Maximum horsepower	11hp	11.2ps
	Maximum power	8.2kw	8.2kw
	Maximum speed	3000rpm	3000rpm
	Displacement	0.13gal	0.479L
	Number of cylinders	2	2
	Cooling method	Water-cooled	Water-cooled
	Engine oil change amount	0.4gal	1.5L
	Fuel form	Diesel	Diesel
Fuel grade	0/-10	0/-10	
Theoretical fuel consumption	0.8-1.2L/h	0.8-1.2L/h	
Body	Transport length	95.7in	2430mm
	Transport width	35.9in	912mm
	Transport height	86.7in	2201mm
	Counterweight ground clearance	14.2in	361mm
	Bucket width	11.8in	300mm
	Boom length	58.1in	1477mm
	Arm length	31.5in	800mm
	Bulldozer blade width	35.9-47.7in	912-1212mm

## ■ HYDRAULIC SYSTEM

Main pump type/model	Gear Pumps 306	Maximum set pressure (Mpa)	18MPa
Main pump brand	Tianjin Walking/Shengjie	Travel hydraulic motor type	WDM-300
Main pump maximum flow (L/min)	18L/min	Travel motor brand	Paiyi
Multi-way valve	2+2+5 way multi-way valve	Motor displacement	315ml/r
Multi-way valve brand	Tengfei	Slewing hydraulic motor type	BM2-315
Rated set pressure (Mpa)	17MPa	Displacement	315ml/r

- Please read the instruction manual carefully and use the machine correctly.
- Always wear a seat belt when working. (ROPS specifications only)
- If you are operating construction machinery with a machine mass of less than 3 tons, you must take the "Special Training for Vehicle-Mounted Construction Machinery Operation" course beforehand. If the machine mass is 3 tons or more, you must take the "Vehicle-Mounted Construction Machinery Operation Skills Course".
- To prevent breakdowns and accidents, be sure to inspect the machinery regularly.
- Specific voluntary inspections are required to be carried out by an inspection company registered with the Minister of Health, Labor and Welfare or the Director-General of the Labor Standards Inspection Bureau.



MINI EXCAVATOR

# R10 ECO



# Ultra compact dimensions superb operator protection minimal tail swing everything you need to get the job done

There's a lot to like about RIPPA's new ultra-compact excavators. They're so compact you can easily work safely in tight spots. They also have an improved control layout\*, and upgraded comfort features to keep you working efficiently and comfortably. Best of all, you can depend on these RIPPA ultra-compact excavators to get the job done with speed and efficiency.



### SIDE LEVER LAYOUT

The control levers of the R10 E60 are positioned to the sides of the seat for a better, more relaxed operator working posture and excellent forward visibility.

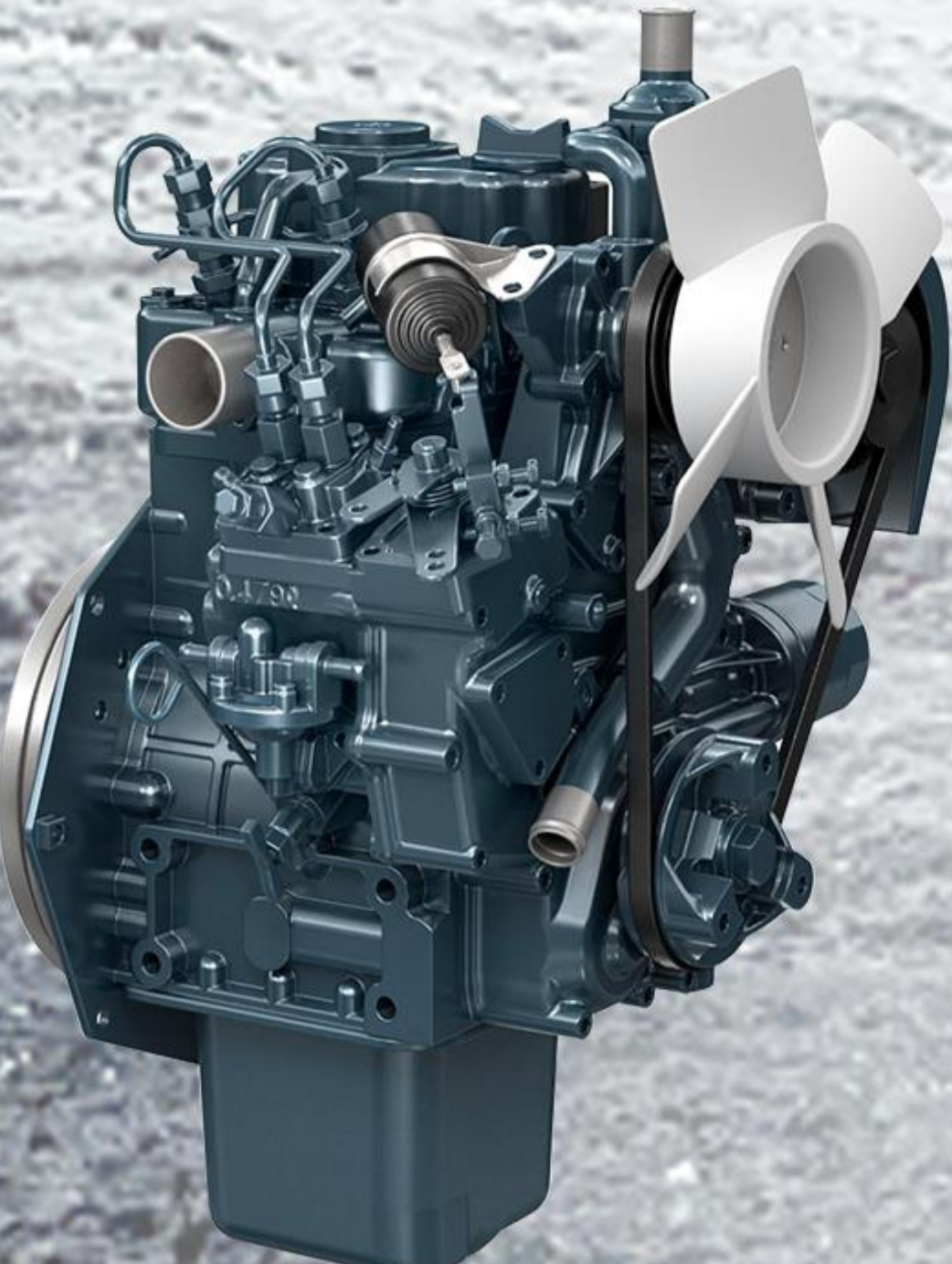

#### RIPPA ULTRA-COMPACT EXCAVATORS



Engine gross horsepower (z482): 11.2 HP (8.2kW)  
Maximum digging force : 9.2 KN  
Operating weight\*\*:978 kg

# PERFORMANCE / SAFETY

From an adjustable track gauge and two-speed travel pedal to Engine Safety Start and a new boom-mounted LED work light, this ultra-compact excavator is designed for maximum performance and safety.

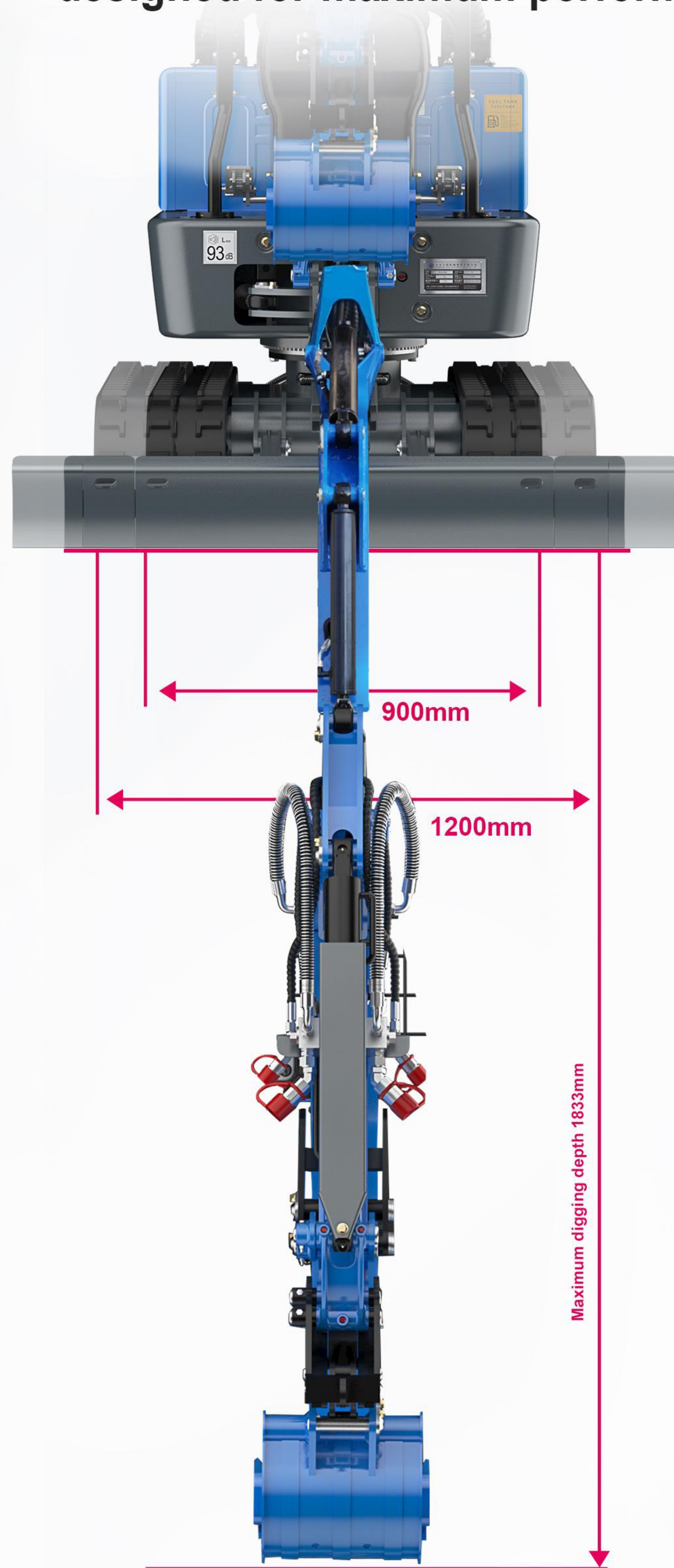

## 1 Adjustable Track Gauge

The R10 eco hydraulically adjustable track gauge can be narrowed down to 900mm in seconds with a simple single lever operation to allow navigation in tight spaces. Conversely, you can widen the track gauge all the way up to 1200mm. Its quick-fold blade adjusts to size instantly with the simple pull of a pin. When adjusted down, these ultra-compact excavators can easily fit through most doorways, allowing access inside buildings.



## 2 Digging Range

The subcompact excavator excels at digging, with a surprisingly wide working and digging range for such a small excavator.



## 3 Large-capacity bucket

Large-capacity bucket can load more materials. The bucket is strong and durable, which greatly improves the working efficiency.



## 4 Lifting hole

More convenient movement and more fixing points for the transport of the machine.

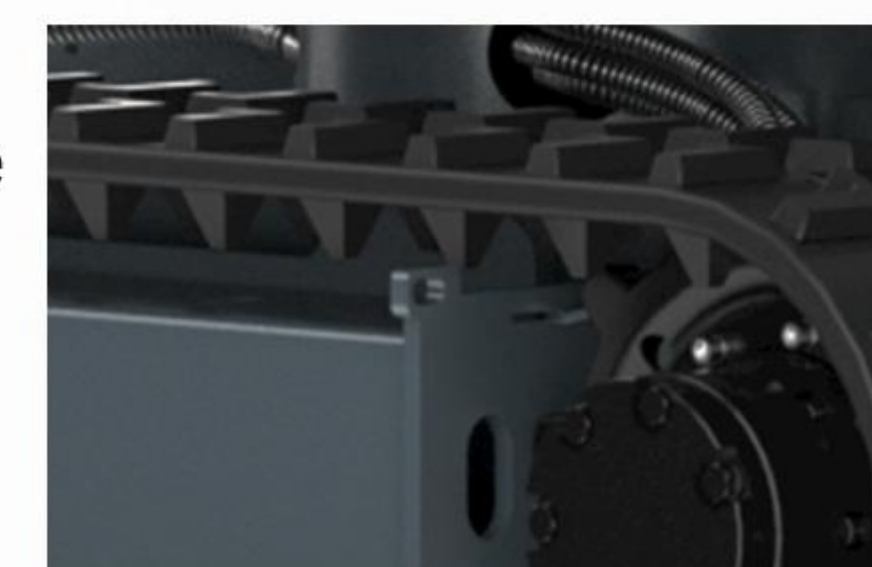

## 5 Roof upgrade

Enhance safety protection and avoid injuries from falling objects; provide clear vision at night or in low light conditions to ensure construction efficiency; expand the driver's field of view, reduce blind spots, and improve operational safety.



## 6 Foot pedal

The foot pedal is set to facilitate the side swing and extension of the excavator, freeing the driver's hands and improving work efficiency.



## 7 Cylinder guard plate

Effectively prevent the impact and scratches of stones, soil, construction debris, etc. on the cylinder, extending the life of the cylinder.

## 8 Four-way crushing pipeline

Four-way high-pressure crushing oil pipe can realize more auxiliary equipment operations.



## 9 Plastic roof cover

The plastic canopy cover is more beautiful and three-dimensional; Compared with iron roofs, it has better waterproof performance and strong corrosion resistance.



The feature of R10 ECO

## Comfortable and safe driving experience



### 1 ACTION BUTTON

The operation buttons are centralized and concise which is convenient for the driver to operate. They are equipped with safety lock and lighting functions which meet the basic operation needs of the operator and effectively improve work efficiency



### 4 CENTRALIZED CONTROL

Integrating the travel and operating levers into one control system allows the operator to control the excavator's travel and working devices at the same time, reducing the need to frequently switch operating handles, making operation easier and more efficient.

### 2 POWER SWITCH

When the excavator is not in use or idle, the operator can cut off the power supply to the equipment through the power switch to avoid energy waste, help the equipment save energy and reduce operating costs



### 3 COMFORTABLE SEATS

Adjustable seat, ergonomically designed to support the operator's back, waist and neck, reducing fatigue caused by long-term operation

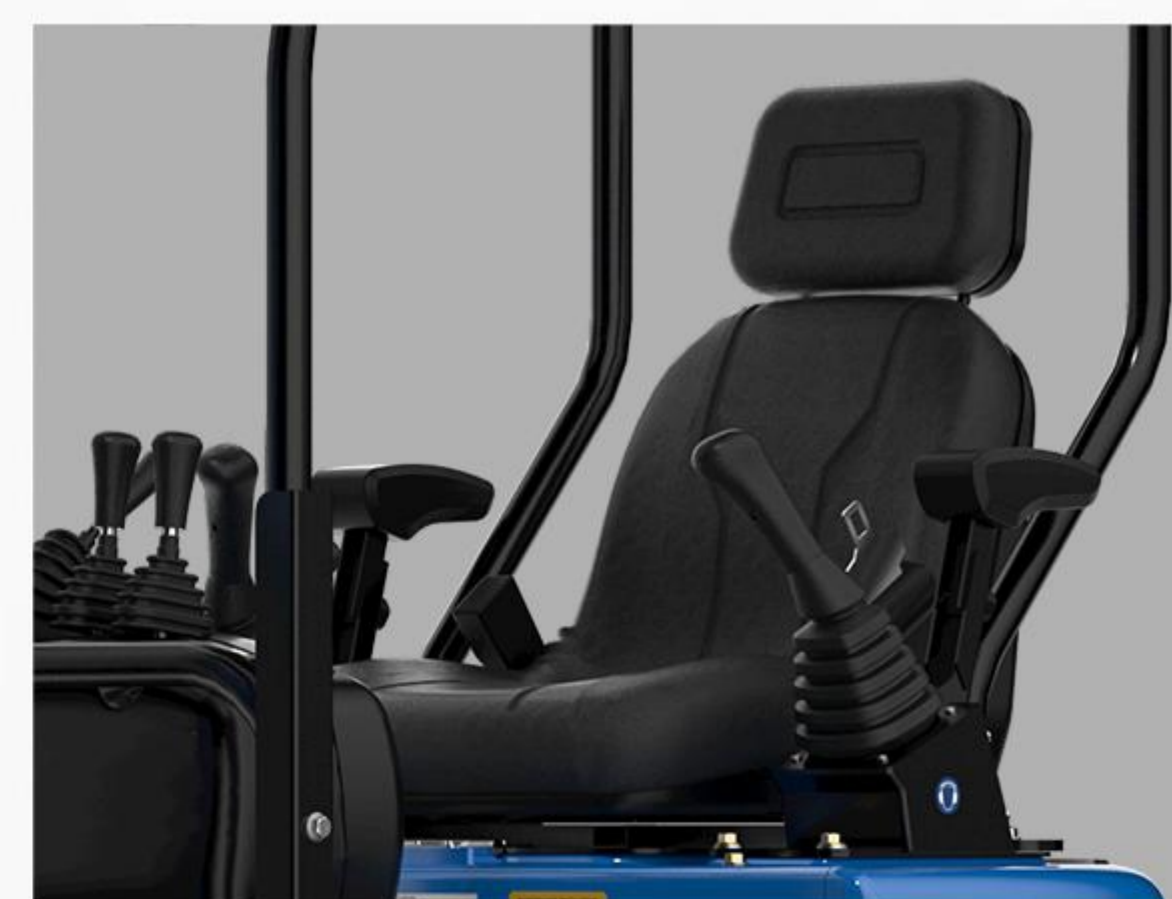

### 5 DASHBOARD

The function area is centralized and the dashboard is set up to facilitate the operator to control the basic status of the vehicle in real time.



The feature of R10 ECO

# SERVICE

The rear opening hood provides easy access to the engine, and maintenance is simple with the hydraulic service port plumbing conveniently located and protected.

## ENGINE COVER

The rear-opening operator seat on the hood can be flipped up to reveal a large portion of the engine, allowing easier access to components



## OIL CIRCUIT MAINTENANCE

A manually openable cover is specially set at the foot pedal, so that when checking the oil circuit and the line, it will be handy and efficient, which provides great convenience for subsequent maintenance and inspection work.



## COUNTERWEIGHT

The excavator counterweight not only ensures the safety of the operation by balancing the torque and improving the stability, but also directly or indirectly improves the operation efficiency, protects the mechanical structure, and expands the operating capacity, which is an indispensable and important component of the excavator to achieve efficient, safe and multi-functional operations.



## SAFETY WARNING LIGHT

When the machine is working or driving, the flashing warning light can remind people on the construction site to keep a safe distance and prevent them from entering dangerous areas by mistake.



## ENTRETIEN DES ROULEMENTS

The pointed butter nozzle is easier to butter, with stop protection, the excavator is not easy to damage the grease nozzle during operation, and the U-shaped stop is easier to clean up the mud.

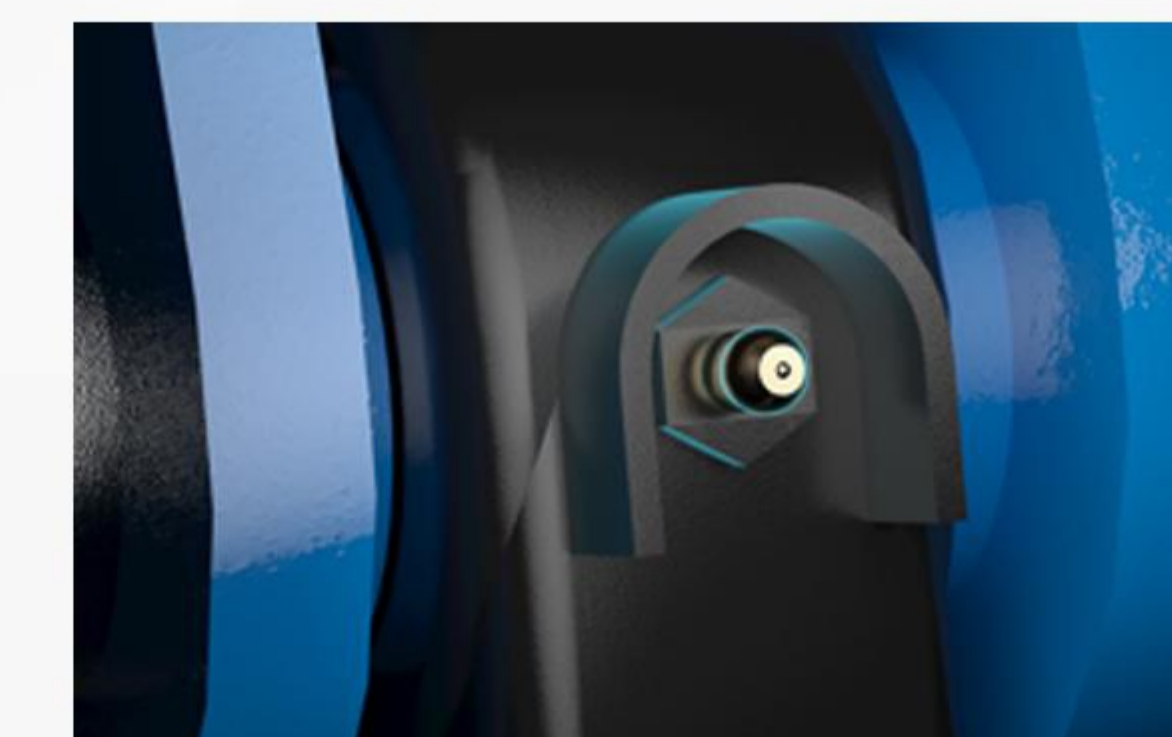

## INTEGRAL INSULATING COTTON APPLICATION

The body guard is equipped with thermal insulation cotton as a whole to improve the thermal insulation effect and avoid the body temperature being too high and causing burns.



# > WE ARE S.G GROUP INDIA

we are located in Pune's Industrial Area, in India. This is a well-trusted Company that imports high-profile construction machinery and sales them. We are known and trusted for providing the customers of India the best sales of construction machines and after-sales services in India.

This is a number one company in trading of construction machinery company.

We are the Best solution for you. The company's employees are energetic and enterprising, constantly creating the legend and fame of the SG GROUP.



Pune-Mumbai Road, Mehata Chambers Kasarwadi, Pune - 411 034

E mail : [info@sggrouppune@gmail.com](mailto:info@sggrouppune@gmail.com) / [sggrouppune@gmail.com](mailto:info@sggrouppune@gmail.com)

Mob : 9850100284 / 9881820284

Web : [www.sggrouppune.com](http://www.sggrouppune.com)

GST No : 27BAEPS0979R1ZP